

Operating Instructions

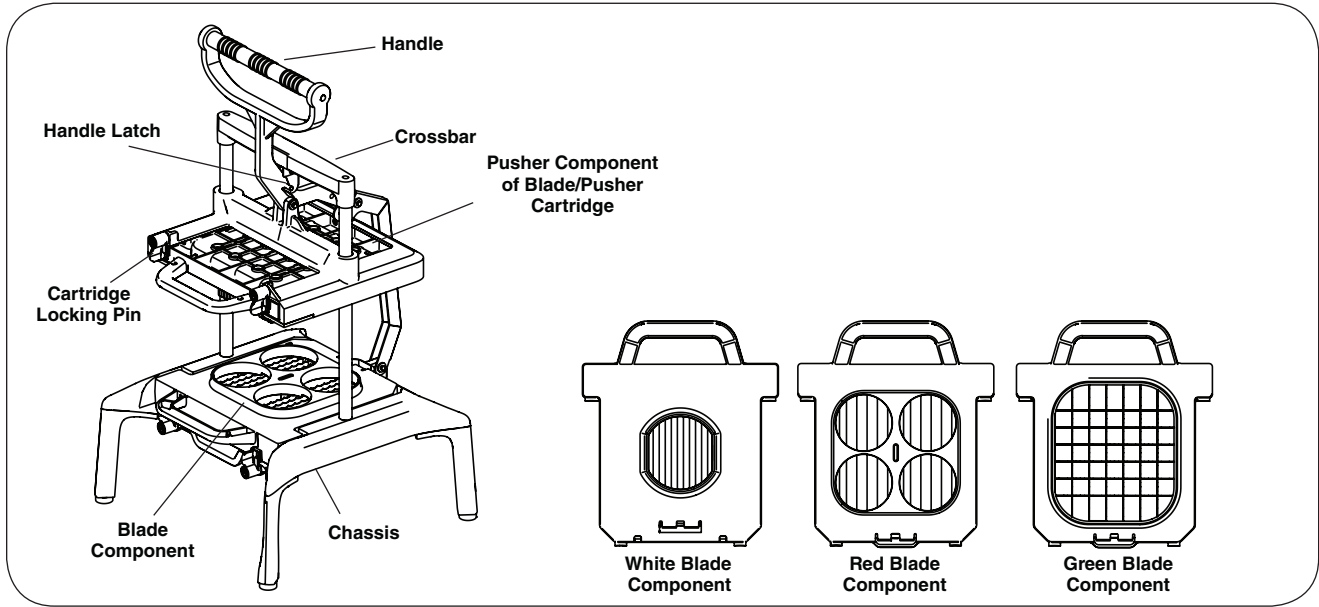

Universal Slicer
Saber King™

Product Identification



LIMITED WARRANTY

This product is warranted to be free from defects in material and/or workmanship for a period of one (1) year from date of original installation, not to exceed 18 months from date of shipment from our factory **with the exception of the blade/pusher cartridge**. Blade/pusher cartridge is warranted to be free from defects at time of delivery only.

Any component which proves to be faulty in material and/or workmanship will be replaced or repaired (at the option of Prince Castle LLC) without cost (including freight and duty) to the customer for parts or labor.

This warranty is subject to the following exceptions/conditions:

- Use of food products other than those specified will void this warranty.
- This equipment is portable; charges for on-location service (e.g., trip charges, mileage) are not included in the provisions of this warranty.
- Damage caused by carelessness, neglect, and/or abuse (e.g., dropping, tampering or altering parts), equipment damaged in shipment, by fire, flood or an act of nature is not covered under this warranty.

TABLE OF CONTENTS

Product Identification	1
Safety Information	2
Important	2
Description.....	2
Specifications	2
Installation	2
Choosing and Inserting a Cartridge.....	3
Operation.....	4
Removing a Cartridge.....	5
Cleaning	5
Exploded View and Parts List	7



MARMON FOODSERVICE TECHNOLOGIES

355 East Kehoe Blvd. • Carol Stream, IL 60188 USA
Telephone: 630-462-8800 • Toll Free: 1-800-PCASTLE
Fax: 630-462-1460 • www.princecastle.com

Safety Information

⚠ WARNING

Indicates information important to the proper operation of the unit. Failure to observe may result in damage to the equipment and/or severe bodily injury or death.

⚠ CAUTION

Indicates information important to the operation of the unit. Failure to observe may result in damage to the equipment.

Description

Prince Castle's Saber King™ is a universal food prep system designed with a multi-purpose chassis and interchangeable blade/pusher cartridges to accommodate slicing a variety of foods all on one slicer. The red cartridge cuts tomatoes into 1/4-inch slices. The green cartridge is a 1-inch by 2-inch cuber for lettuce. The white cartridge makes 3/16-inch slices of onions, cucumbers, peppers and more. This space-saving slicer has patented blade covers and requires both hands to operate, making it safe and easy to use and clean.

Important

Prince Castle reserves the right to change specifications and product design without notice. Such revisions do not entitle the buyer to corresponding changes, improvements, additions or replacements for previously purchased equipment.

Specifications

Approximate Dimensions and Weight

Height	23.0" (58.4 cm)
Width	16.4" (41.7 cm)
Depth	16.2" (41.1 cm)
Shipping Weight	30.0 lbs (13.6 kg)

Installation

- 1 Remove the unit from the carton and inspect for signs of damage.** If there is damage to the unit:
- Notify carrier within 24 hours after delivery.
 - Save carton and packing materials for inspection purposes.
 - Contact the Prince Castle Customer Sales Department at 1-800-722-7853 to arrange for a replacement to be sent.

- 2 Verify that all parts have been received.**
- Chassis
 - Red Blade/Pusher Cartridge
 - White Blade/Pusher Cartridge
 - Green Blade/Pusher Cartridge
 - Cleaning Brush, P/N 943-042

- 3 Place chassis on a prep table or other flat surface.**

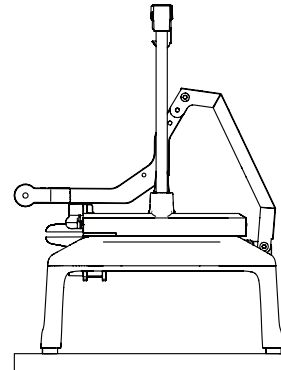

- 4 Perform initial cleaning.** Refer to the instructions under *Cleaning* in this manual.

Choosing and Inserting a Cartridge

CAUTION
Choose the red cartridge for tomatoes only and choose the green cartridge for lettuce only. Use of the red or green cartridges for other foods may damage the blades.

- 1 Choose the blade/pusher cartridge for the food product you want to prepare.**
Red Cartridge – For slicing tomatoes.
Green Cartridge – For cubing lettuce.
White Cartridge – For slicing onions and other similarly textured foods.
- 

2 Ensure the handle on the chassis is down. If necessary, place one hand on the handle and the other hand on the crossbar. Use your thumb to open the handle latch and then pull the handle down.

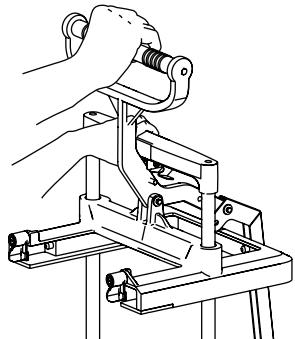

3 Move the cartridge locking pins to the unlocked position. Move the two upper cartridge locking pins and the two lower cartridge locking pins to their horizontal positions so the cartridge can be inserted.

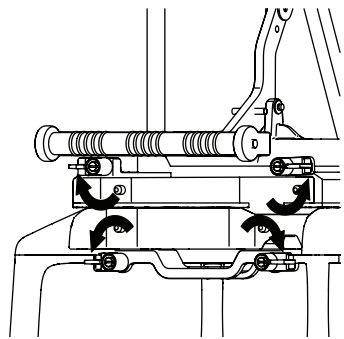

4 Holding the pusher and blade components together as one cartridge, insert into the chassis. With the pusher component facing up (solid face), guide the sides of the pusher component into the C-shaped channel in the chassis. The blade component will automatically be correctly inserted.

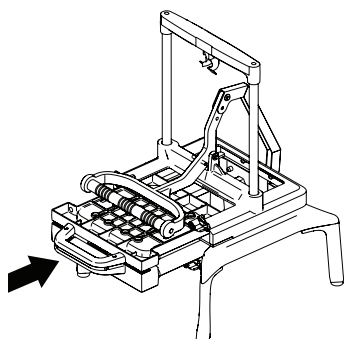

5 Move the cartridge locking pins to the locked position. Move the two upper cartridge locking pins and the two lower cartridge locking pins to their vertical positions so the components will stay aligned in the chassis.

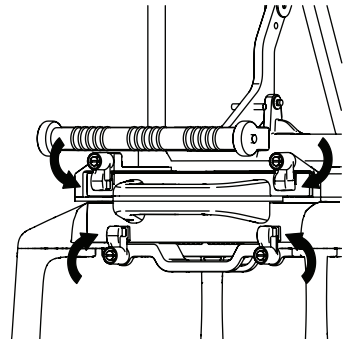

CAUTION
The four locking pins must be in the locked position during operation to prevent damage to the blades.

Operation

1 Ensure the handle on the chassis is up. If necessary, place one hand on the handle and the other hand on the crossbar. Pull the handle up, and the handle latch will hold the handle in the "up" position.

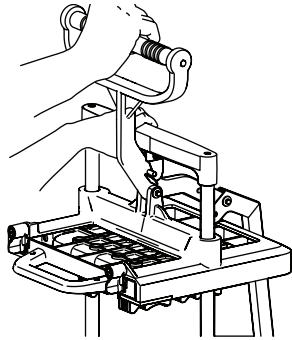

4 Put a pan or bowl under the slicer to catch the food as it is cut.

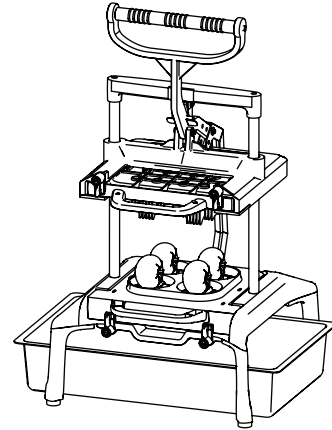

2 Ensure the cartridge locking pins are in the locked (vertical) position.

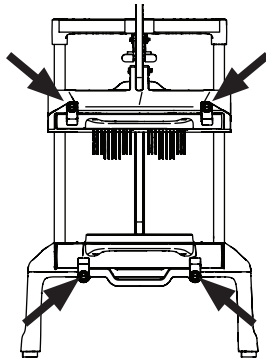

5 Pull the handle on the chassis down. Place one hand on the handle and the other hand on the crossbar. Use your thumb to open the handle latch and then pull the handle swiftly down.

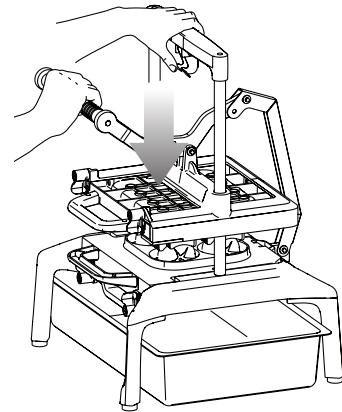

3 Place the food product onto the blade component. Shaped guides on the red and white cartridges indicate how the food should be positioned. For tomatoes, make sure to point their stemmed ends toward the right or left to slice across them correctly. The white cartridge has flat sides on the shaped guide for stemmed ends of onions and other similar foods.

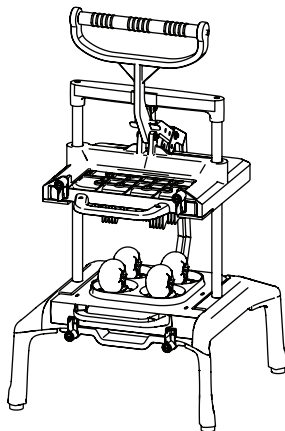

Removing a Cartridge

- 1** Ensure the handle on the chassis is down. If necessary, place one hand on the handle and the other hand on the crossbar. Use your thumb to open the handle latch and then pull the handle down.

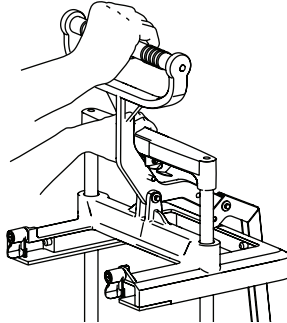

- 2** Move the cartridge locking pins to the unlocked position. Move the two upper cartridge locking pins and the two lower cartridge locking pins to their horizontal positions so the cartridge can be removed.

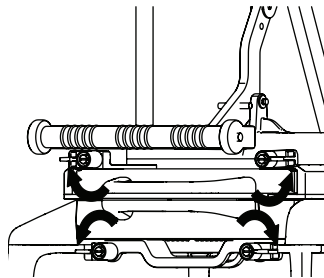

- 3** Holding the pusher and blade components together as one cartridge, remove from the chassis. Guide the sides of the pusher component out of the C-shaped channel in the chassis.

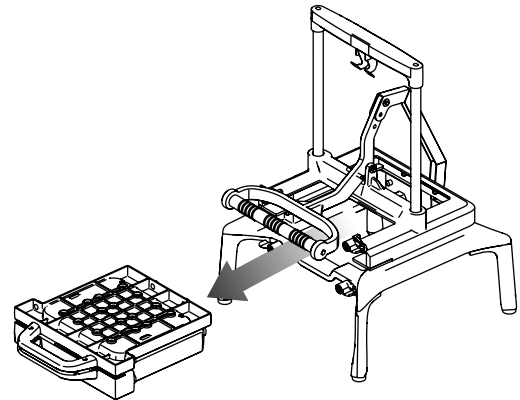

Cleaning

Daily cleaning will keep this universal slicer clean and free from buildup.

⚠ CAUTION

Do not allow residual food juices to remain on the blade component for long periods. A hard deposit may form on the blades which is difficult to remove and will dull the blades.

- 1** Gather tools and supplies you will need for cleaning.

- Cut-resistant gloves
- Three compartment sink
- Cleaning brush, P/N 943-042
- Cleaning solution
- Sanitizing solution



Cleaning (continued)

2 Remove the blade/pusher cartridge from the chassis. Refer to the instructions under *Removing a Cartridge* in this manual.

3 Carry the blade/pusher cartridge to the three-compartment sink. Put on the cut-resistant gloves. Separate the blade and pusher components.

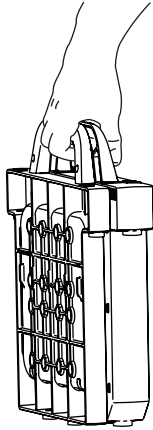

4 Clean the blade and pusher components in the sink. Using the cleaning brush, scrub off any residue.

NOTE: For the blade component, be sure to scrub in the direction of the blade.

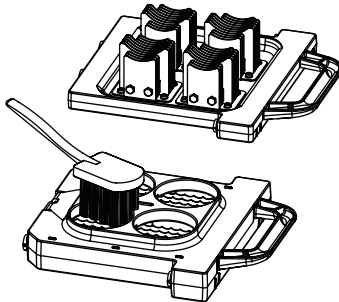

5 Rinse and sanitize the blade and pusher components.

6 Assemble the sanitized blade and pusher components. Let the assembled cartridge air dry.

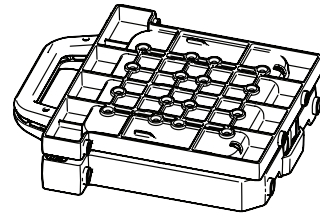

7 Clean, rinse and sanitize the exterior surfaces of the chassis. Wipe the chassis first with a cleaning solution, then with clear water and finally with sanitizing solution. Let the surfaces air dry.

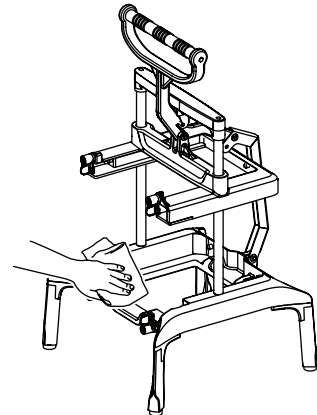

Exploded View and Parts List

Parts Breakdown

No.	Part No.	Description
1		Crossbar and Latch Assembly
2		Handle Assembly
3		Red Pusher Cartridge Component
4		White Pusher Cartridge Component
*		Green Pusher Cartridge Component
6		Green Blade Cartridge Component

No.	Part No.	Description
7		White Blade Cartridge Component
8		Red Blade Cartridge Component
9		Leg (Qty. 4)
10		Cartridge Locking Pin (Pkg. of 4)

* Not Shown

