

HP19-26

Prince Castle's HP19-26 heater panels use infrared heaters that hold fried foods longer, have a better appearance, and are in better condition than foods held with cal rod heaters or heat lamps.

Work with your dealer / fabricator to determine what size heater panel you need and the best way to install.

STANDARD FEATURES

- Create heat that holds fried foods longer and better than calrods and heat lamps.
- Minimizes the heat bleeding out of the heated area, thus providing a more comfortable work environment for your employees.
- Installs easily into stainless steel fabrication.
- Can be retrofitted into most existing fabrication that utilizes cal rods or heat lamps.
- The use of the HPC-2 controller allows the heater panels to cycle on and off thus increasing energy efficiency.

HEAT
R
PANEL

HP19-26 Series 01/05

355 East Kehoe Blvd. • Carol Stream, IL 60188 • Tel: (630) 462-8800 • Fax: (630) 462-1460 • Toll Free: 1-800-PCASTLE • www.princecastle.com

HP19-26 SERIES HEATER PANEL

PRINCE CASTLE INC.
WORLDWIDE
A Marmen Retail Services Company

SPECIFICATIONS

DIMENSIONS

MODEL NO.	DESCRIPTION	LENGTH IN. (CM)	DEPTH IN. (CM)	HEIGHT
HP19-26	Heater panel	18.27	25.74	3.49

ELECTRICAL

MODEL	VOLT	Hz.	WATT	AMP
HP19-26	208-240	50/60	1290	6.2

REQUIRED ACCESSORY

- HPC-2 Heater Panel Controller

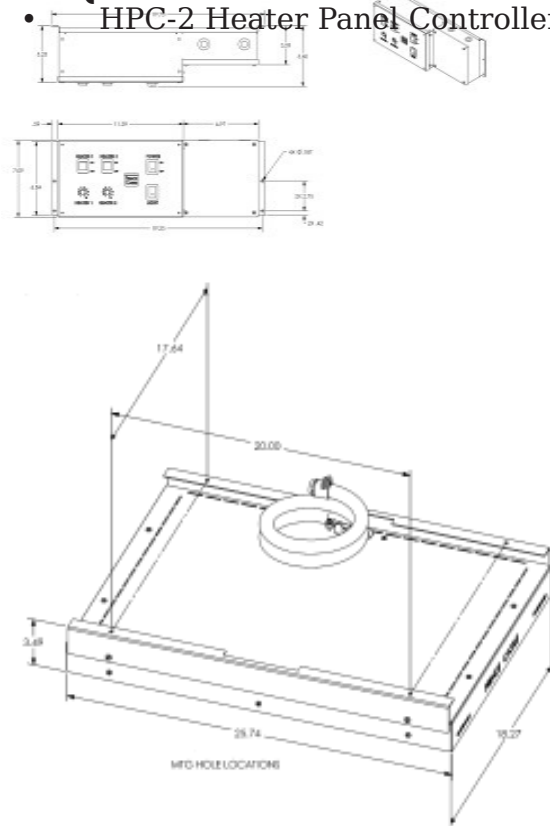

HEATER PANEL

P19-26

HP19-26

HPL19-26

355 East Kehoe Blvd. • Carol Stream, IL 60188 • Tel: (630) 462-8800 • Fax: (630) 462-1460 • Toll Free: 1-800-PCASTLE • www.princecastle.com